

PRODUCT DATA SHEET

PRODUCT CODE: DKF700

DESCRIPTION: PP-IML Container for Food Packaging



TECHNICAL DRAWINGS & PICTURES

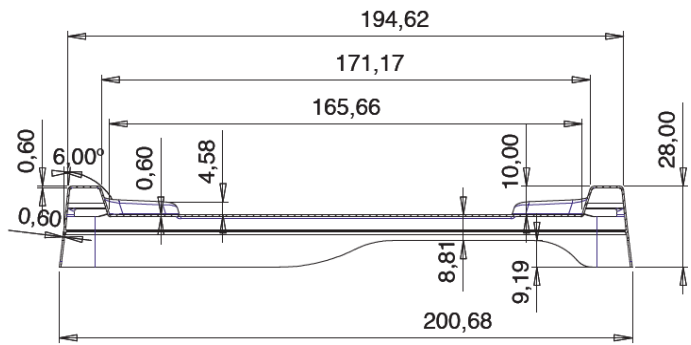
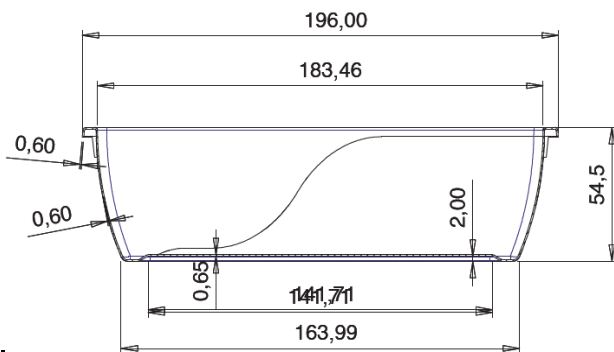
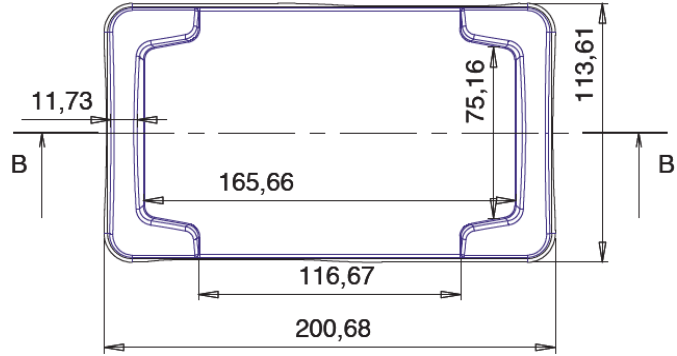
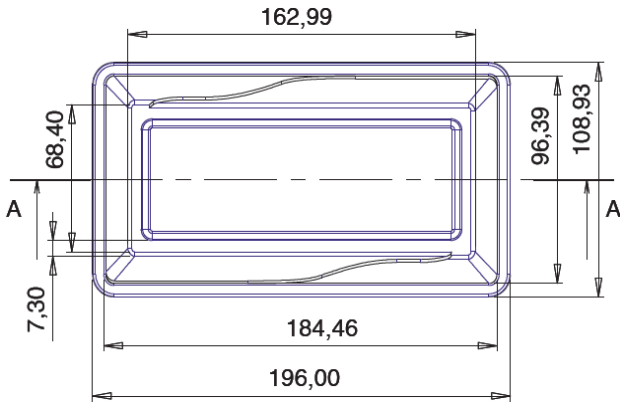

MATERIAL, COLOR, QUALITY CONTROL and WEIGHT

Containers and lids are produced by polypropylene in grades approved for food packaging according to New Code for Foodstuff and beverages 1998, Chapter II, Art.26.

Both lid and the container are food grade for human consumption.

DKF700 container and lid can be produced with all colors as per the demand of the customer.

Production is certificated according to EN ISO 9001:2000.

Container: 27gr (±%5)

Lid: 21 gr (±%5)

Volume: 700 ml

100%
Recyclable
PP Material



LOGISTIC & PALLETISING

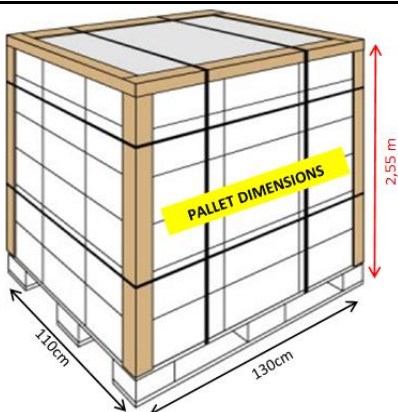

Quantity per Pallet	:	11.520 pieces	(Tub)
Quantity per Pallet	:	19.200 pieces	(Lid)
Quantity per Truck	:	158.400 sets	(Set = Body + Lid)
Quantity per 40'HC Container	:	129.600 sets	(Set = Body + Lid)
Quantity per 20'DC Container	:	43.200 sets	(Set = Body + Lid)

