

PRODUCT DATA SHEET

PRODUCT CODE: DÖK1130

DESCRIPTION: PP-IML Container for Food Packaging



TECHNICAL DRAWINGS & PICTURES

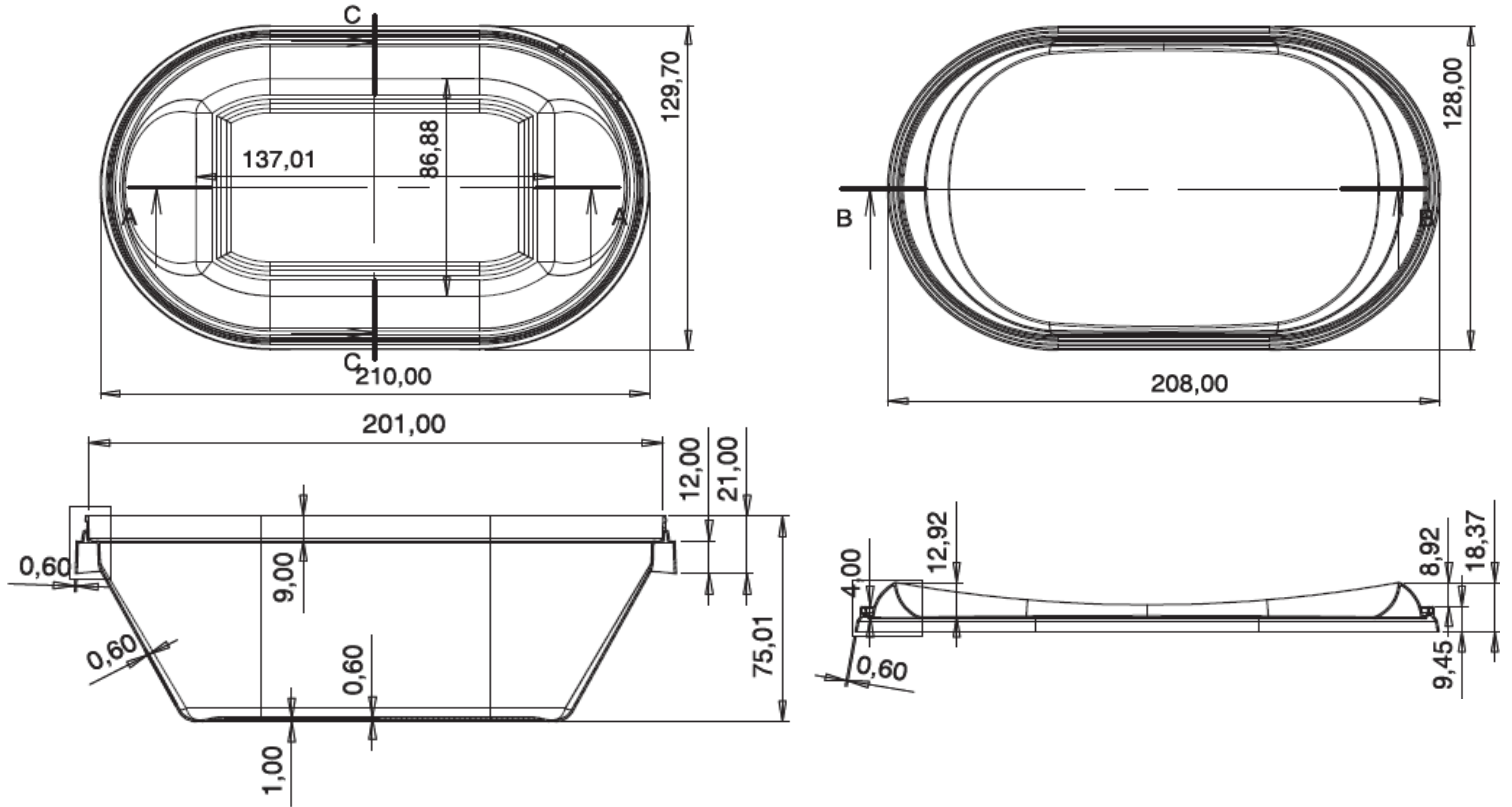

MATERIAL, COLOR, QUALITY CONTROL and WEIGHT

Containers and lids are produced by polypropylene in grades approved for food packaging according to New Code for Foodstuff and beverages 1998, Chapter II, Art.26.
Both lid and the container are food grade for human consumption.

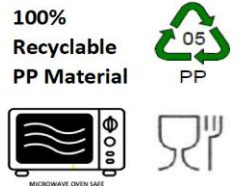

DÖK1130 container and lid can be produced with all colors as per the demand of the customer.
 Production is certificated according to EN ISO 9001:2000.
 Container: 37.6 gr (±%5) Lid: 20.6 gr (±%5) Volume:1160 ml

LOGISTIC & PALLETISING

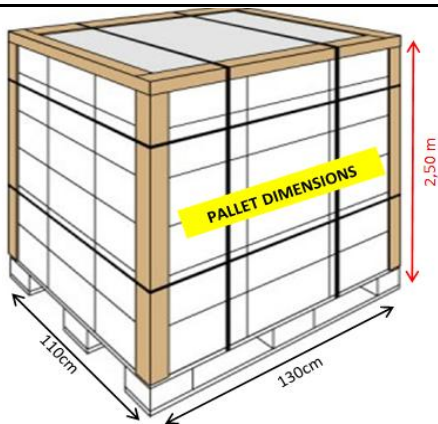

Quantity per Pallet	:	6.944 pieces	(Tub)
Quantity per Pallet	:	29.160 pieces	(Lid)
Quantity per Truck	:	113.900 sets	(Set = Body + Lid)
Quantity per 40'HC Container	:	93.200 sets	(Set = Body + Lid)
Quantity per 20'DC Container	:	33.650 sets	(Set = Body + Lid)

