

# PRODUCT DATA SHEET

PRODUCT CODE: DKF300

DESCRIPTION: PP-IML Container for Food Packaging



## TECHNICAL DRAWINGS & PICTURES

Tub / Kutu

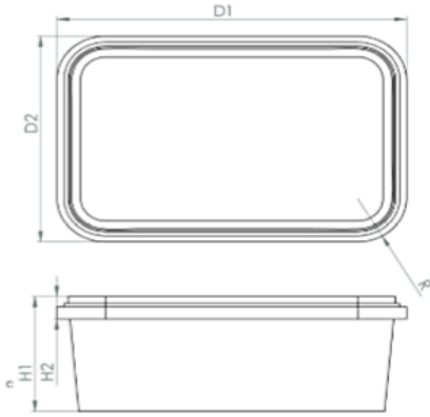

D1=142,5±1 mm  
D2=92,5±1 mm  
H1=43,0±1 mm  
H2=10±0.5 mm

Lid / Kapak

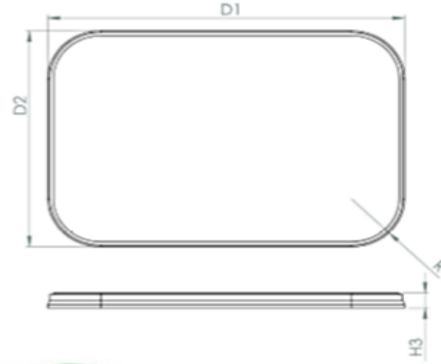

D1=146,5±1 mm  
D2=96,5±1 mm  
H3=12,5±0.5 mm



## MATERIAL, COLOR, QUALITY CONTROL and WEIGHT

Containers and lids are produced by polypropylene in grades approved for food packaging according to New Code for Foodstuff and beverages 1998, Chapter II, Art.26.

Both lid and the container are food grade for human consumption.

DKF300 container and lid can be produced with all colors as per the demand of the customer.

Production is certificated according to EN ISO 9001:2000.

Container: 13,5 gr (±0,5)      Lid: 9,5 gr (±0,5)      Volume: 300 ml

100%  
Recyclable  
PP Material



## LOGISTIC & PALLETISING

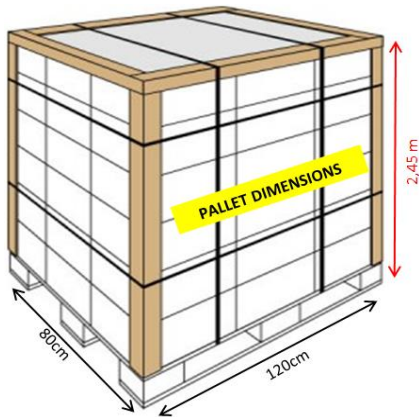

Box Dimensions	:	60*40*47 cm	(w * l * h)
Boxes per Pallet	:	20	
Quantity per Pallet	:	14.000 pieces	(Tub)
Quantity per Pallet	:	28.800 pieces	(Lid)
Quantity per Truck	:	310.800 sets	(Set = Body + Lid)
Quantity per 40'HC Container	:	226.036 sets	(Set = Body + Lid)
Quantity per 20'DC Container	:	103.600 sets	(Set = Body + Lid)

