

# PRODUCT DATA SHEET

PRODUCT CODE: DKF350

DESCRIPTION: PP-IML Container for Food Packaging



## TECHNICAL DRAWINGS & PICTURES

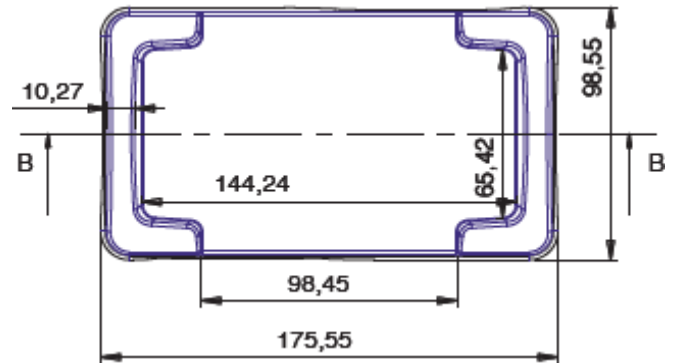
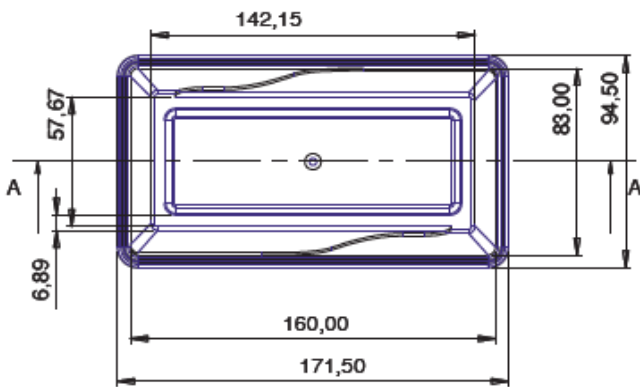
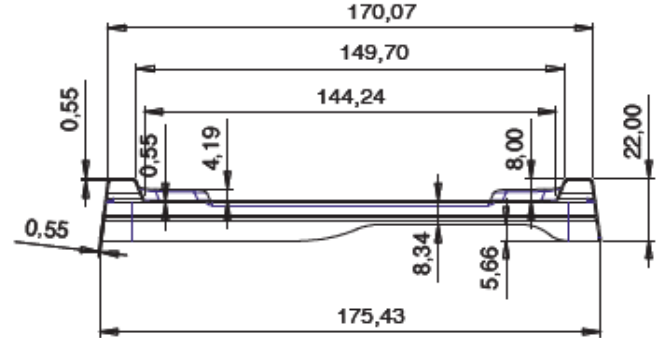
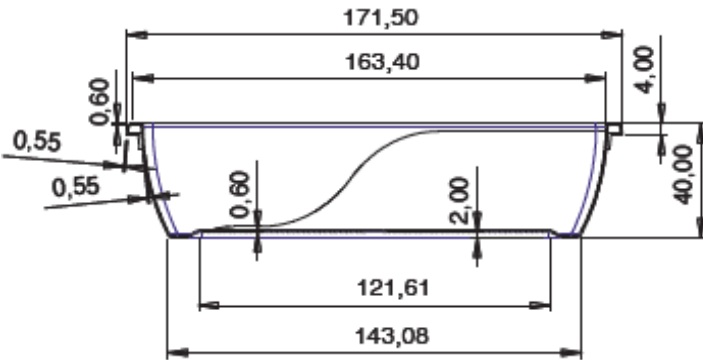

## MATERIAL, COLOR, QUALITY CONTROL and WEIGHT

Containers and lids are produced by polypropylene in grades approved for food packaging according to New Code for Foodstuff and beverages 1998, Chapter II, Art.26.

Both lid and the container are food grade for human consumption.

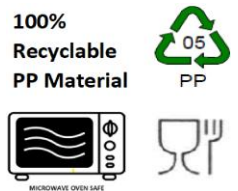

DKF350 container and lid can be produced with all colors as per the demand of the customer.

Production is certificated according to EN ISO 9001:2000.

Container: 16,5 gr (±%2)      Lid: 12,5 gr (±%2)      Volume: 350 ml

## LOGISTIC & PALLETISING

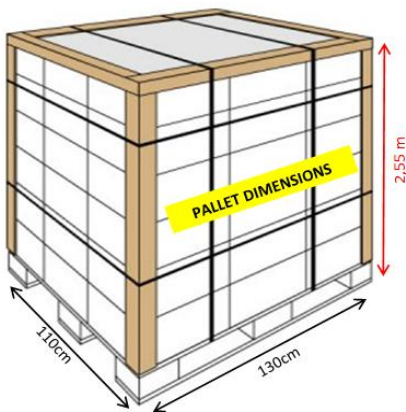

|                              |   |               |                    |
|------------------------------|---|---------------|--------------------|
| Quantity per Pallet          | : | 14.400 pieces | (Tub)              |
| Quantity per Pallet          | : | 21.600 pieces | (Lid)              |
| Quantity per Truck           | : | 190.080 sets  | (Set = Body + Lid) |
| Quantity per 40'HC Container | : | 155.520 sets  | (Set = Body + Lid) |
| Quantity per 20'DC Container | : | 51.840 sets   | (Set = Body + Lid) |

