

PRODUCT DATA SHEET

PRODUCT CODE: DKF230

DESCRIPTION: PP-IML Container for Food Packaging



TECHNICAL DRAWINGS & PICTURES

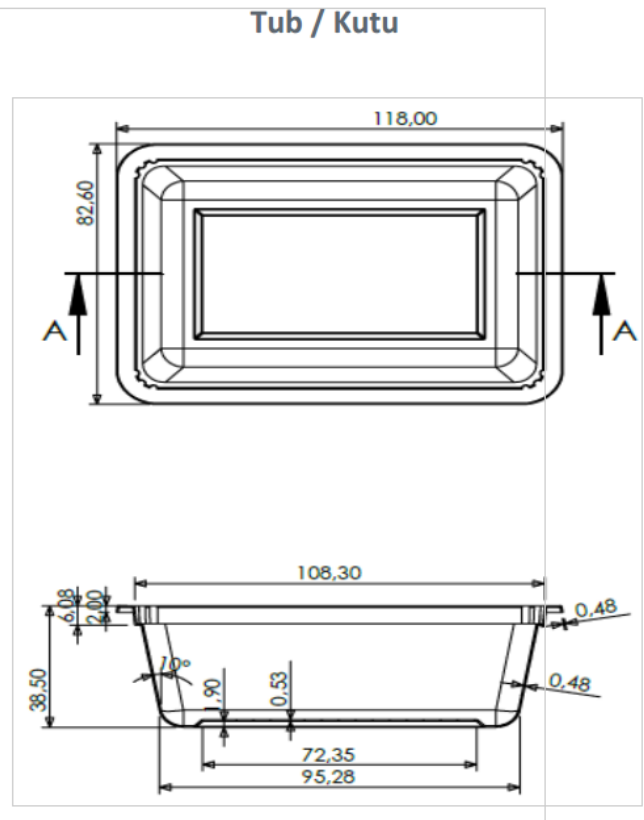
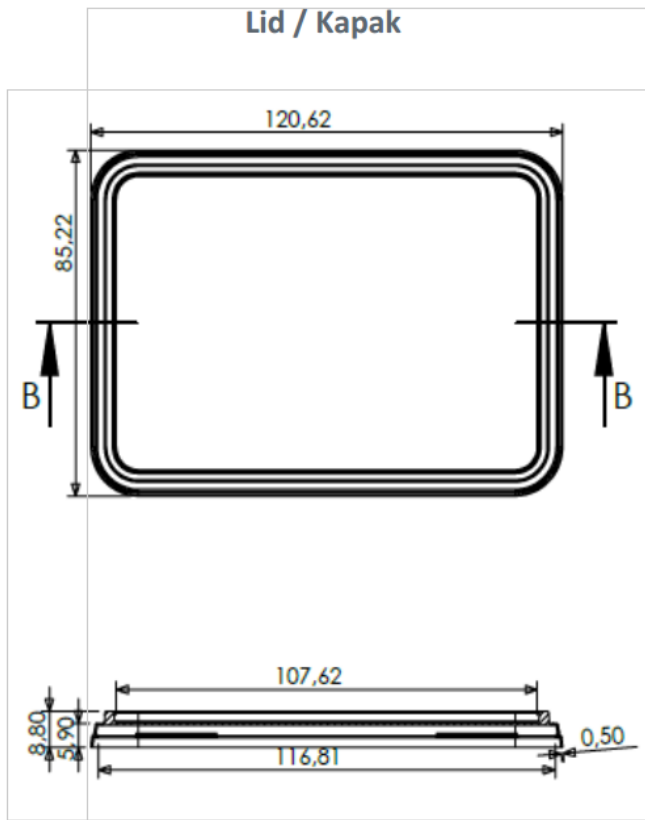

MATERIAL, COLOR, QUALITY CONTROL and WEIGHT

Containers and lids are produced by polypropylene in grades approved for food packaging according to New Code for Foodstuff and beverages 1998, Chapter II, Art.26.

Both lid and the container are food grade for human consumption.

DKF230 container and lid can be produced with all colors as per the demand of the customer. Production is certificated according to EN ISO 9001:2000.

Container: 9 gr ± %5 Lid: 6,5 gr ± %5 Volume: 230 ml

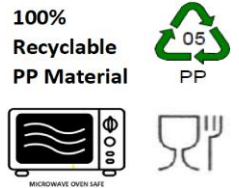

LOGISTIC & PALLETISING

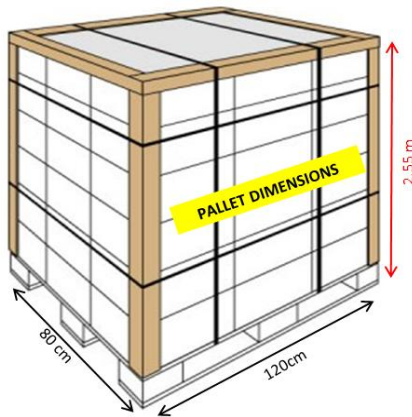

Quantity per Pallet	:	20800 pieces	(Tub)
Quantity per Pallet	:	20800 pieces	(Lid)
Quantity per Truck	:	343.00 sets	(Set = Body + Lid)
Quantity per 40'HC Container	:	249.600 sets	(Set = Body + Lid)
Quantity per 20'DC Container	:	91.520 sets	(Set = Body + Lid)

