

PRODUCT DATA SHEET

PRODUCT CODE: DÖK1301

DESCRIPTION: PP-IML Container for Food Packaging



TECHNICAL DRAWINGS & PICTURES

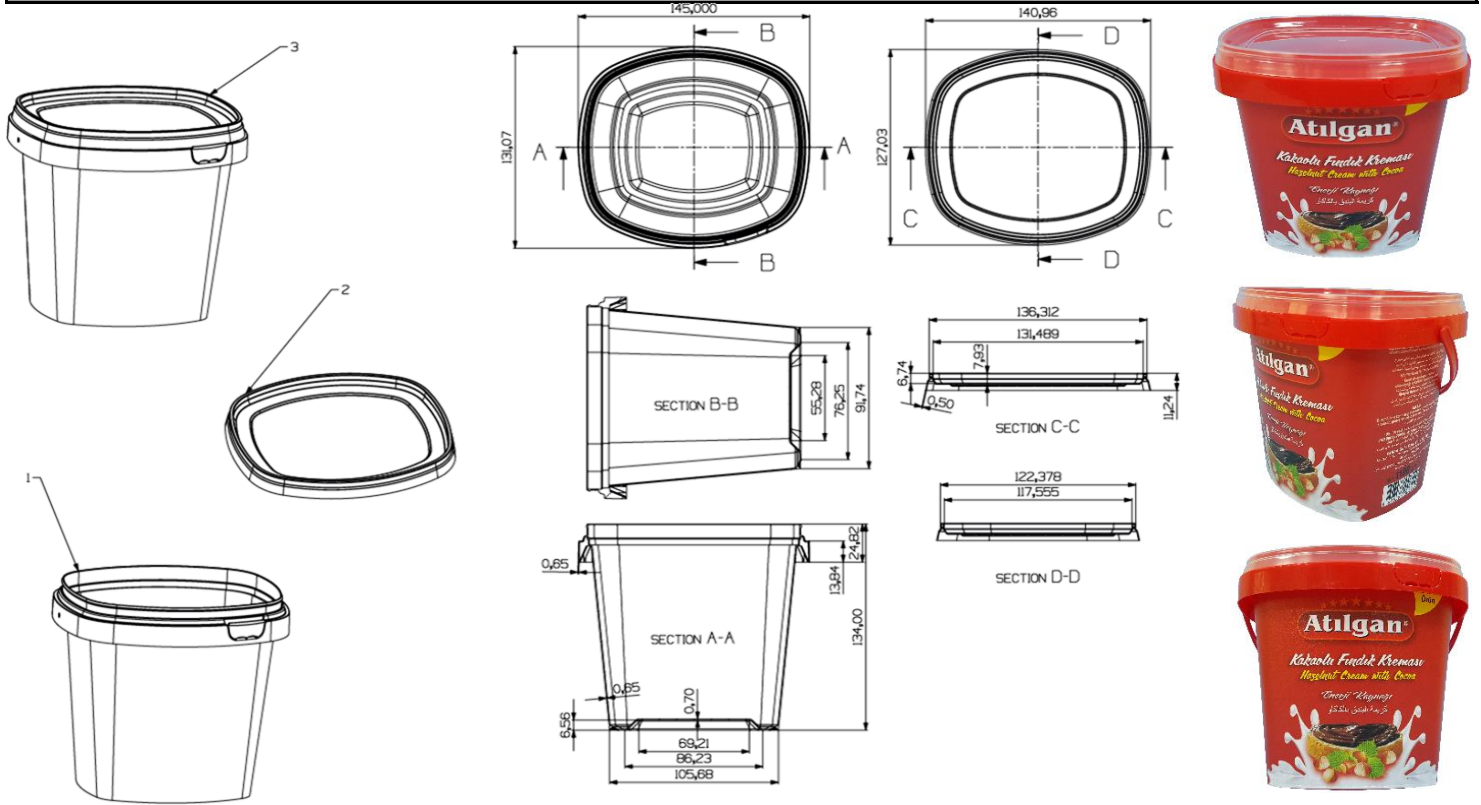

MATERIAL, COLOR, QUALITY CONTROL and WEIGHT

Containers and lids are produced by polypropylene in grades approved for food packaging according to New Code for Foodstuff and beverages 1998, Chapter II, Art.26. Both lid and the container are food grade for human consumption.



DÖK1301 container and lid can be produced with all colors as per the demand of the customer. Production is certificated according to EN ISO 9001:2000.

Container: 40,0 gr (±1) Lid: 11,0 gr (±0,5) Volume: 1 LT



LOGISTIC & PALLETISING

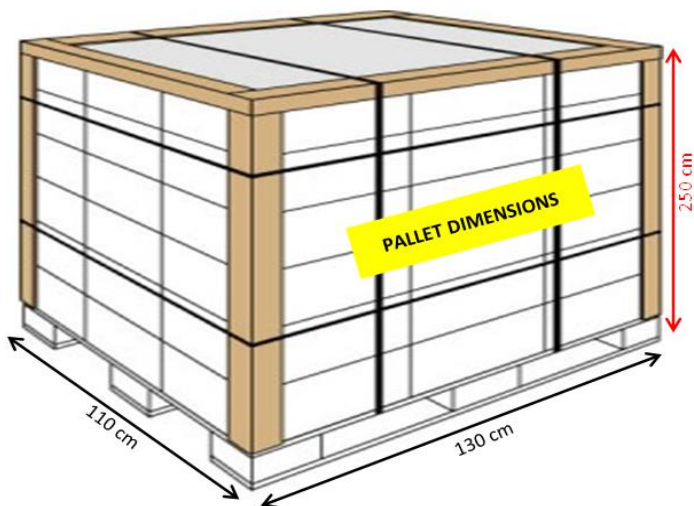

Carton Box Dimensions	:	43*55*60 cm (w*I*h)
Quantity / Carton Box	:	320 pcs (body)
Quantity / Carton Box	:	1.600 pcs (lid)
Carton Boxes / Pallet	:	24 pcs
Quantity / Pallet	:	7.680 pcs (body)
Quantity / Pallet	:	6.400 (sets)
Qty per Truck	:	140.800 sets
Qty per 40'HC Container	:	115.200 sets
Qty per 20'DC Container	:	51.200 sets

